

STEELCOAT 400™ SYSTEM



A reinforced tape system for the protection of above ground pipe and steelwork

The Steelcoat 400™ System comprises deep penetrating primer (Denso Penetrating Primer™), an easily applied layer fabric backed tape (Denso Ultraseal™ Tape) and a topcoat (Denso Acrylic Topcoat™). The final topcoat can be reinforced with a selected reinforcing scrim (Denso D5™ or Denso D10™ Scrim) for sections of steelwork or pipework which require additional impact resistance.

After priming, Denso Profiling Mastic™ is first utilised to seal and profile back-to-back angles, voids, flanges or fittings, before application of Denso Ultraseal Tape and selected topcoat. Ideal for badly pitted or rusted steel structures.

FEATURES

- Cold applied
- Surface tolerant
- Highly conformable
- Proven performance
- Easily repaired and over-coated
- Low future maintenance costs

COMPONENTS

Denso Penetrating Primer™

Denso Ultraseal™ Tape

Denso Acrylic Topcoat™

Options:

Denso Profiling Mastic™

For sealing voids and awkward shapes.

Denso D5™ or Denso D10™ Scrim

For extra reinforcement.

SURFACE PREPARATION

Minimal surface preparation required. Surfaces must be clean and dry. Remove all loose rust, scale and flaking coatings by hand power tool.

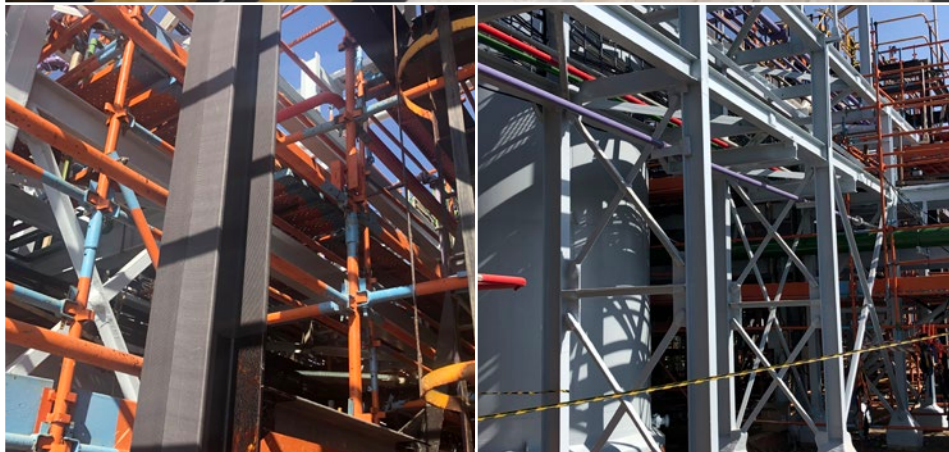

LAYER 1:
DENSO PENETRATING
PRIMER™ &
DENSO ULTRASEAL™ TAPE

LAYER 2:
DENSO ACRYLIC TOPCOAT™

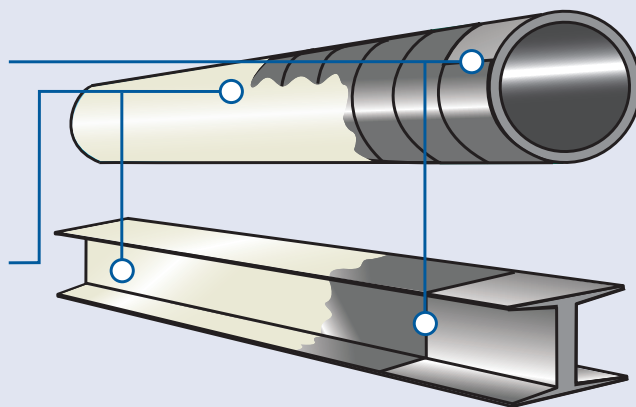

PUB No. 496.05.2020



FM 01548 | EMS 583748
ISO 9001:2015 & ISO 14001:2015

WINN & COALES (DENSO) LTD

TEL: +44 (0) 208 670 7511
FAX: +44 (0) 208 761 2456
EMAIL: mail@denso.net
WEB: www.denso.net

Winn & Coales (Denso) Ltd
33 - 35 Chapel Road
London SE27 0TR
UNITED KINGDOM



A MEMBER OF WINN & COALES INTERNATIONAL